

Gable End Instructions

A Gable Ended Tent consist's of the following components:

- Perimeter Poles Yellow Dot
- Keder Rafters Blue/Green Dot
- Perimeter Poles Yellow Dot (Cut at 65° for the gable end)
- Gable End Upright No Color (attaches perimeter to crown cluster)
- Gable End Crown Cluster Flat
- Gable End Corner Brackets Left and Right Hand Brackets with flat side
- Gable End Intermediate Bracket for attachment of the upright to the special perimeter poles
- Gable End Leg Assembly - Special cut with 1" adjustment holes and adjustable base plate
- Roof Tension Cables to provide strength to the gable end side of the tent

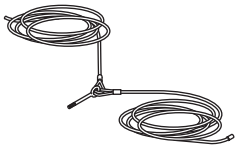

Roof Tension Cable - Set

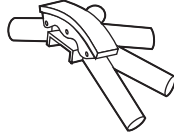

Gable End Crown Cluster

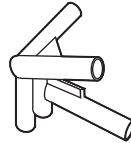

Gable End Corner Bracket

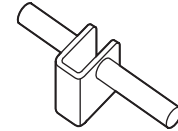

Gable End Intermediate Bracket

Step 1: Lay out all components for your job requirements. The assembly process involve the same techniques used in the Future Trac or Future Lite assembly process. The following outlines the variations of this assembly process.

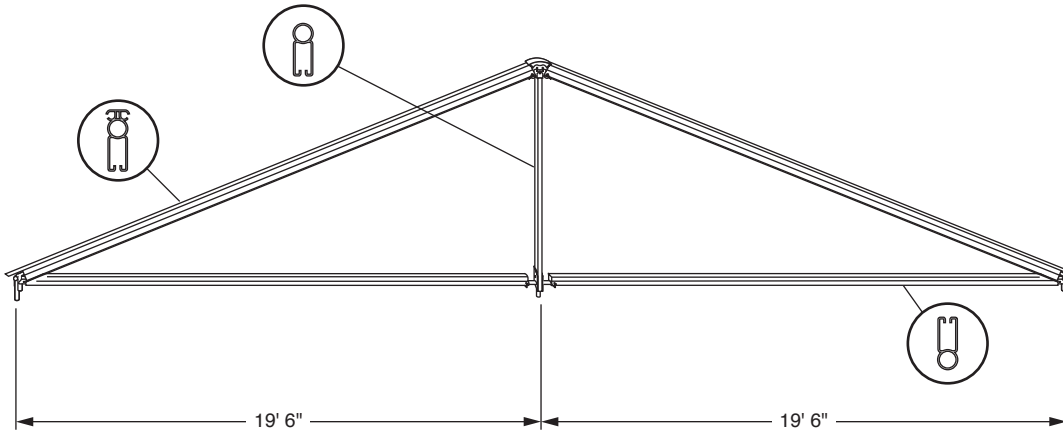

Upon completion the gable end frame should take on this configuration prior to leg installation. Assembly is similar to the Future Trac assembly process in that the arch assembly is built first, using Keder rafters, crown clusters (gable end), corner brackets (gable end), and roof tension cables. The only difference is the addition of a gable end upright and special intermediate bracket. See the illustrations below for the assembly process.

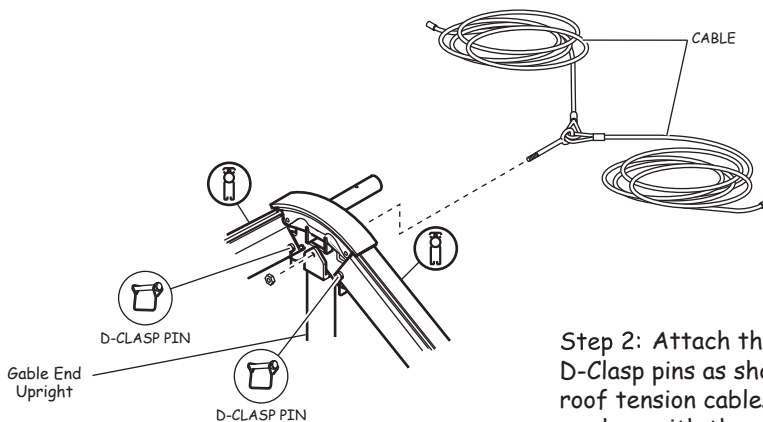

Step 2: Attach the Keder rafters to the gable end crown cluster using D-Clasp pins as shown. Using one set (two cables with an eye bolt) of roof tension cables attach the gable end upright to the crown cluster as show with the ny-lock nut to the outside as shown.

Gable End Instructions

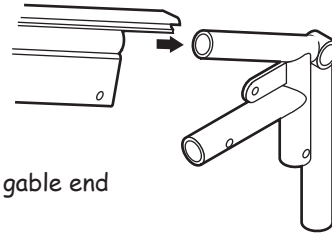
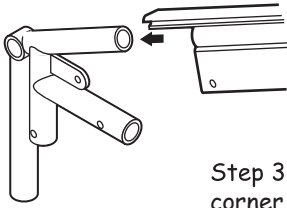

Step 3: Attach the Keder rafters to the gable end corner brackets with D-Clasp Pins.

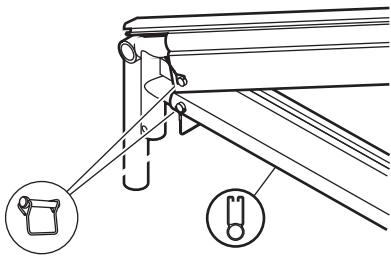

D-CLASP PIN

Step 4: Attach the special perimeter poles (yellow dot) to the corner bracket and pin with a D-Clasp pin, as shown. Please note that these poles have a 65° cut to the same angle as the Keder rafter for clearance. Pole is placed with the open side facing up.

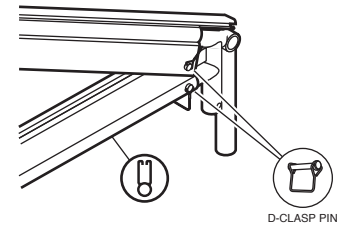

D-CLASP PIN

Step 5: Attach the gable end upright to the intermediate bracket as shown. Please note, that the offset portion of this bracket is installed to the upright with a $3/8$ " cap screw. Do not tighten fully at this time. Next, slide the gable end perimeter poles onto the intermediate bracket. Do not pin until both poles are installed.

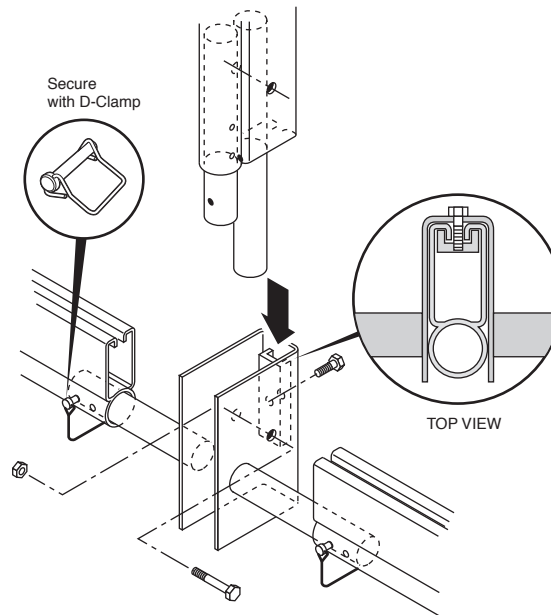

Gable End Instructions

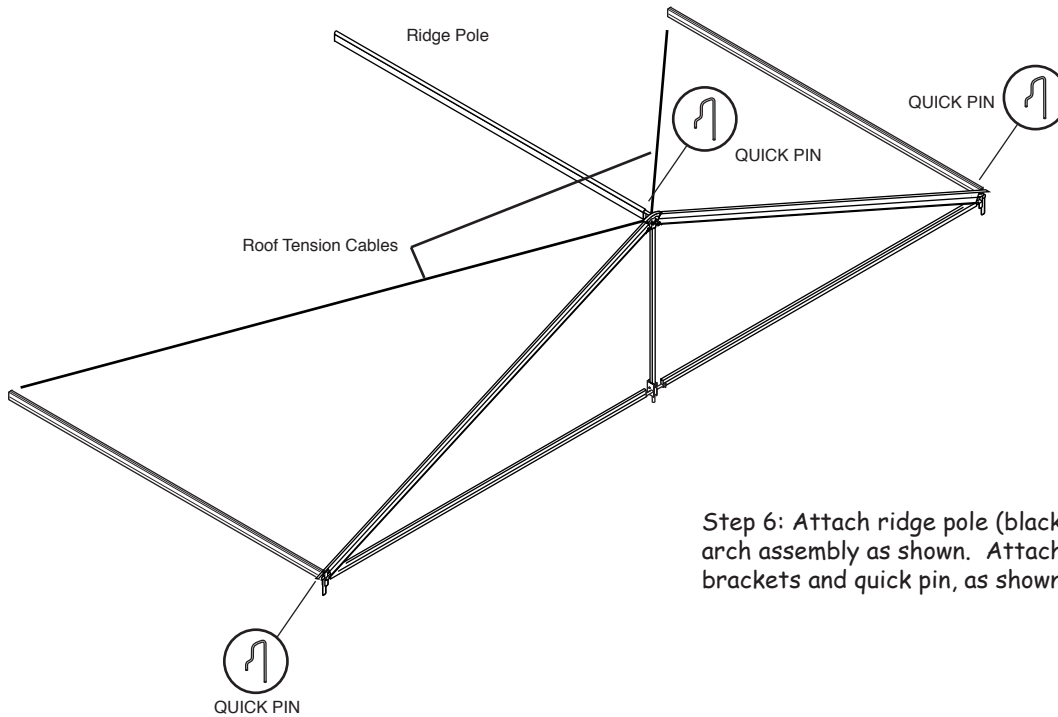

Step 6: Attach ridge pole (black dot), quick pin and raise arch assembly as shown. Attach perimeter poles to corner brackets and quick pin, as shown.

Step 7: Build next arch assembly as show below, using the same procedures as building the first arch assembly.

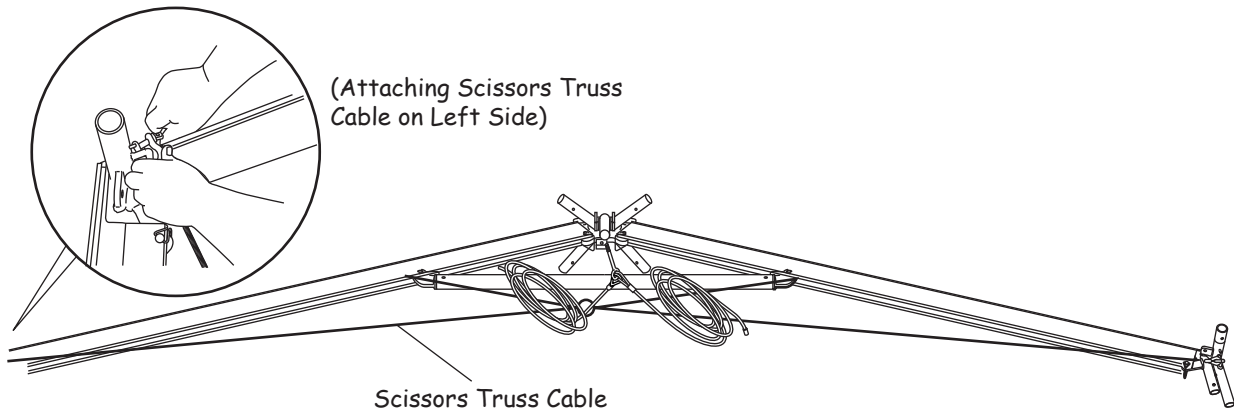

Once the brace bar has been installed, connect both of the long ends of the scissors truss cables with the clevis pin (as shown) to the intermediate brackets. Next, pull the frame inward from each intermediate bracket and use 3/8" D-Clasp Pins to pin the short ends of the scissors truss cables to the Keder rafters at the holes below the brace bar. This is a designed pre-load.

Next, attach the roof tension cable set to the crown cluster with the eye bolt as shown. Tighten fully and lay out cables over the top of the scissors truss cable already attached. This will allow the roof tension cables to fall out of the way when raising the arch assembly.

Attach ridge pole and raise arch assembly and attach to the first completed arch assembly.

Gable End Instructions

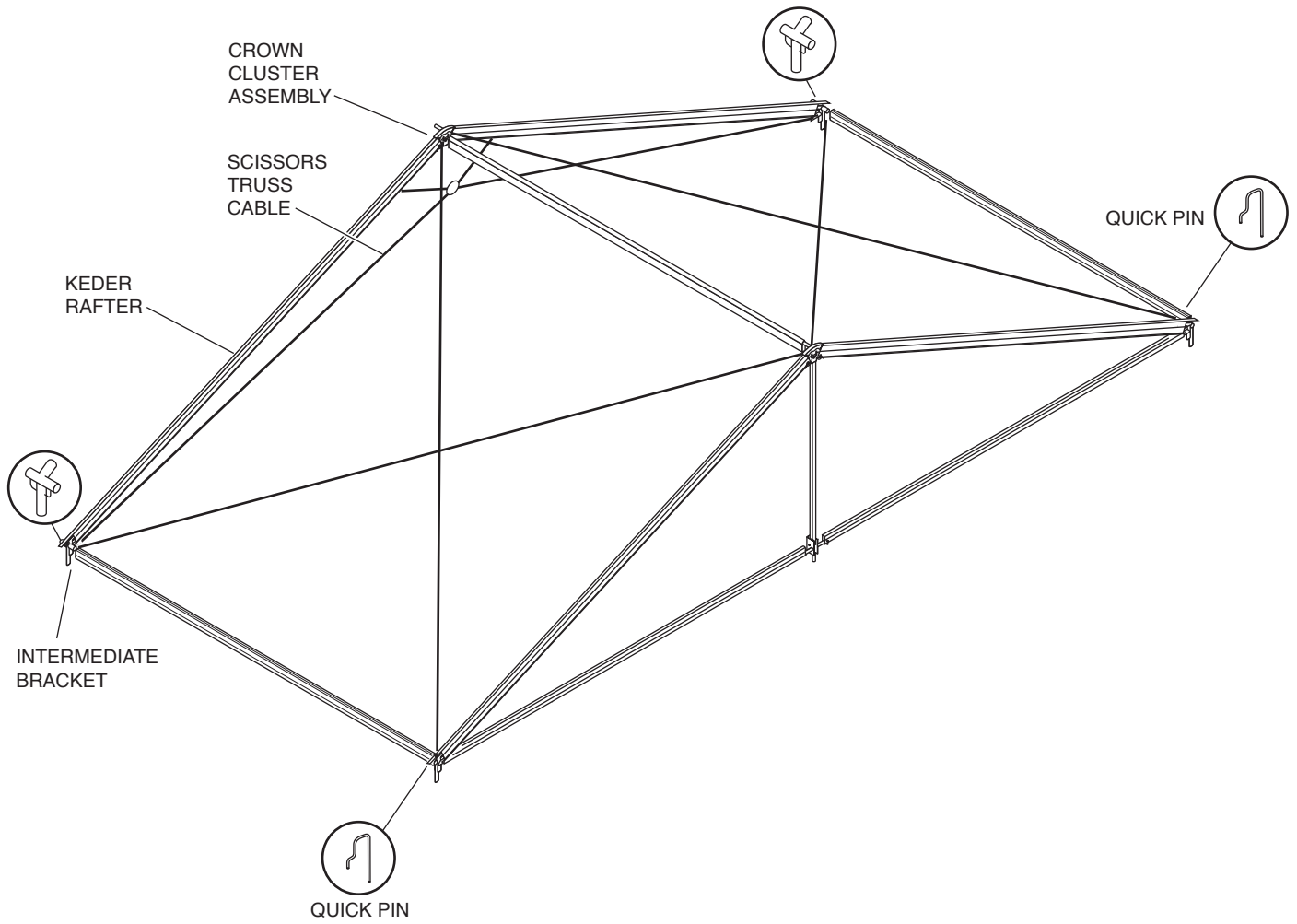

Completed end section of Gable Tent is show above. Additional mids may be installed as in the previous steps and the remaining gable end section would appear as shown above.

You now have the option of installing the tops or raising the frame onto its legs, then installing the tops.